

SRS Warning Light does not Come ON

DESCRIPTION

See page RS-229.

WIRING DIAGRAM

See page RS-229.

INSPECTION PROCEDURE

1 CHECK BATTERY

- (a) Measure the voltage of the battery.
Standard voltage:
 11 to 14 V

NG → **CHECK AND REPLACE BATTERY OR CHARGING SYSTEM**

OK

2 CHECK CONNECTOR (INSTRUMENT PANEL WIRE - COMBINATION METER)

- (a) Turn the ignition switch off.
- (b) Disconnect the negative (-) terminal cable from the battery, and wait for at least 90 seconds.
- (c) Check the instrument panel wire connector and terminals (on the combination meter side) and check that the connector is properly connected to the combination meter.

Result

Result	Proceed to
No problem.	A
Connector or terminals incorrect.	B
Connector connected improperly.	C

B → **REPAIR OR REPLACE INSTRUMENT PANEL WIRE**

C → **CONNECT CONNECTOR@PROPERLY**

A

3 CHECK SOURCE VOLTAGE (COMBINATION METER)

- (a) Disconnect the connector from the combination meter.
- (b) Connect the negative (-) terminal cable to the battery, and wait for at least 2 seconds.

RS

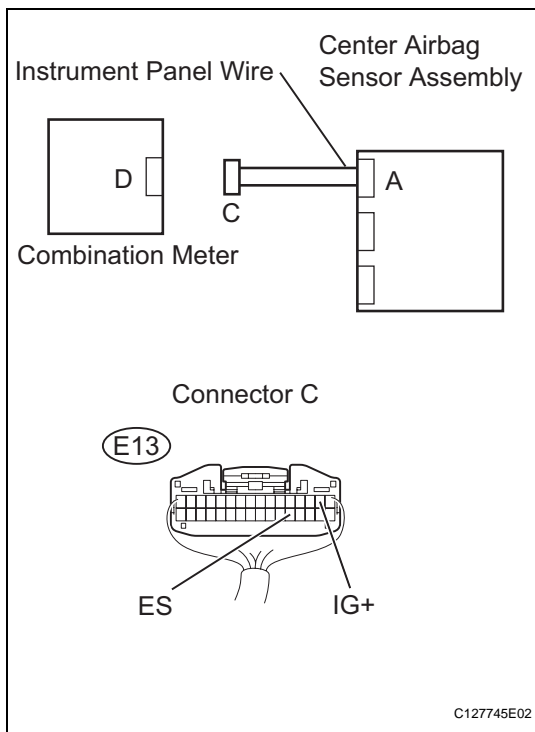

- (c) Measure the voltage.
Standard voltage

Tester Connection	Condition	Specified Condition
E13-2 (IG+) - Body ground	Ignition switch on	11 to 14 V

- (d) Turn the ignition switch off.
- (e) Measure the resistance.

Standard resistance

Tester Connection	Condition	Specified Condition
E13-21 (ES) - Body ground	Always	Below 1 Ω

NG REPAIR OR REPLACE HARNESS OR CONNECTOR

OK

4 CHECK CONNECTOR (INSTRUMENT PANEL WIRE - CENTER AIRBAG SENSOR ASSEMBLY)

- (a) Turn the ignition switch off.
- (b) Disconnect the negative (-) terminal cable from the battery, and wait for at least 90 seconds.
- (c) Check the instrument panel wire connector and terminals (on the center airbag sensor assembly side) and check that the connector is properly connected to the center airbag sensor assembly.

Result

Result	Proceed to
No problem.	A
Connector or terminals incorrect.	B
Connector connected improperly.	C

B REPAIR OR REPLACE INSTRUMENT PANEL WIRE

C CONNECT CONNECTOR @ PROPERLY

A

RS

C127745E02

5 CHECK INSTRUMENT PANEL WIRE

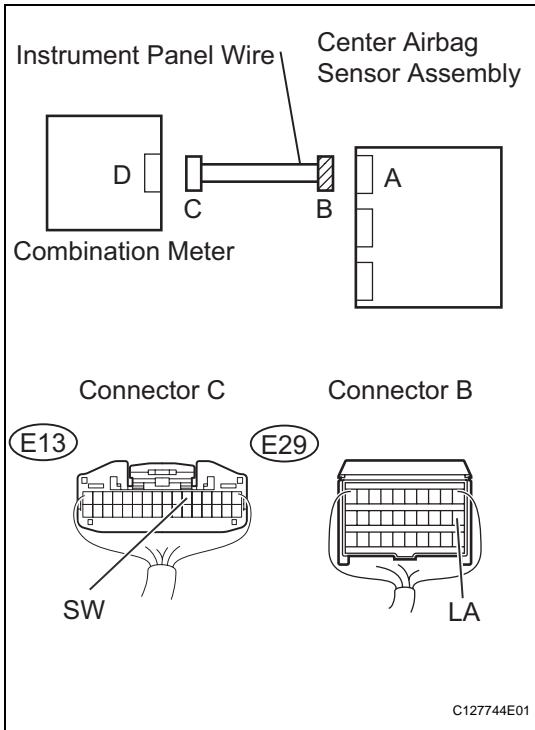

- (a) Disconnect the connectors from the center airbag sensor assembly and combination meter.
- (b) Check for short to B+ in the circuit.
 - (1) Connect the negative (-) terminal cable to the battery, and wait for at least 2 seconds.
 - (2) Turn the ignition switch on.
 - (3) Measure the voltage.

Standard voltage

Tester Connection	Condition	Specified Condition
E13-6 (SW) - Body ground	Ignition switch on	Below 1 V

- (c) Check for open in the circuit.
 - (1) Turn the ignition switch off.
 - (2) Disconnect the negative (-) terminal cable from the battery, and wait for at least 90 seconds.
 - (3) Measure the resistance.

Standard resistance

Tester Connection	Condition	Specified Condition
E13-6 (SW) - E29-11 (LA)	Always	Below 1 Ω

- (d) Check for short to ground in the circuit.
 - (1) Measure the resistance.

Standard resistance

Tester Connection	Condition	Specified Condition
E13-6 (SW) - Body ground	Always	1 MΩ or higher

RS

NG REPAIR OR REPLACE INSTRUMENT PANEL WIRE

OK

6 CHECK SRS WARNING LIGHT

- (a) Connect the connector to the combination meter.
- (b) Connect the negative (-) terminal cable to the battery, and wait for at least 2 seconds.
- (c) Turn the ignition switch on.
- (d) Check the SRS warning light condition.

OK:

The SRS warning light goes off after the primary check period and comes on again after approximately 10 seconds.

HINT:

The primary check period lasts for approximately 6 seconds after the ignition switch is turned on.

NG GO TO COMBINATION METER SYSTEM

OK

REPLACE CENTER AIRBAG SENSOR ASSEMBLY